



三禮電子集團控股有限公司

3L ELECTRONIC GROUP HOLDINGS LIMITED
SPECIFICATION FOR APPROVED 樣品承認書



CUSTOMER:

PAGE : 1 OF 3

P/N(料號): SNR3015K-SERIES

YOUR REF. :

1.MACHANCIAL DIMENSIONS(外形尺寸):

DRAW. NO. : SNR3015K

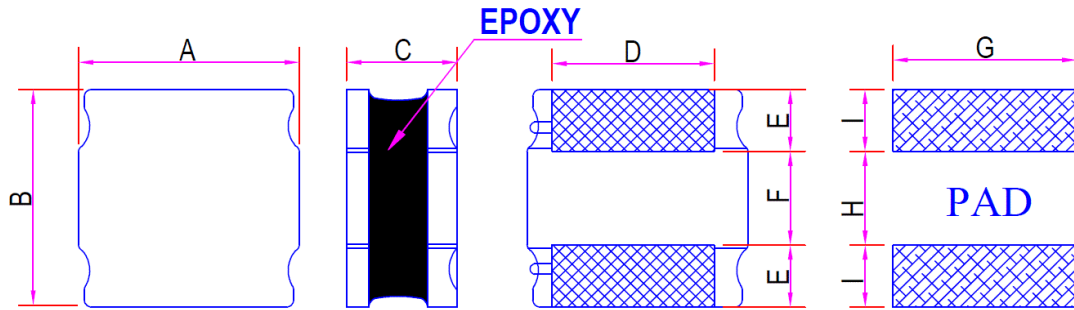

SCHEMATIC



原理圖

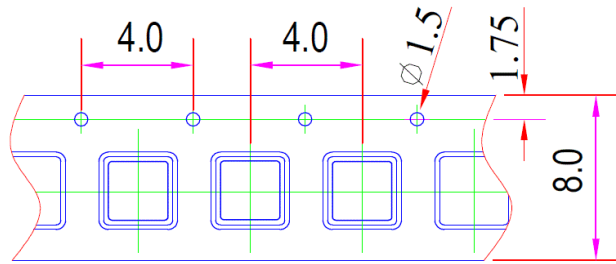

EACH TAPE : 2000 PCS

Item (項目)	Spec. (規格mm)	Typ.(實測值)	Item (項目)	Spec. (規格mm)	Typ.(實測值)
A	3.0+0.2		F	1.5	
B	3.0+0.2		G	2.7	
C	1.5 Max		H	1.5	
D	2.7		I	0.8	
E	0.75		K		

2. NOTES (備注, 包括印字及起始同相端等特別要求):

2.1 Marking (印字):

CUSTOMER APPROVED (客戶確認)

APPROVED (確認)

CHECKED (檢查)

DRAWN (制圖)



ISSUED DATE(出版日期): 20161014

PRINT DATE(出圖日期): 20161014

REV(版次): XA



三禮電子集團控股有限公司

3L ELECTRONIC GROUP HOLDINGS LIMITED

SPECIFICATION FOR APPROVED 樣品承認書



CUSTOMER: PAGE : 2 OF 3

P/N(料號): SNR3015K-SERIES YOUR REF. :

3. ELECTRICAL CHARACTERISTICS (電特性要求):

3L/PN	L	Tolerance	DCR(mΩ)	Isat	Irise	Test Freq
	(uH)	(+-%)	(+-30%)	(A)	(A)	Condition
SNR3015K-R30N	0.30	30	15	4.60	3.50	1MHz/0.25V
SNR3015K-R47N	0.47	30	20	4.00	3.50	100KHz/0.25V
SNR3015K-1R0N	1.0	30	30	2.32	2.10	100KHz/0.25V
SNR3015K-1R5N	1.5	30	50	2.00	1.70	100KHz/0.25V
SNR3015K-1R8N	1.8	30	55	1.75	1.65	100KHz/0.25V
SNR3015K-2R2N	2.2	30	60	1.60	1.60	100KHz/0.25V
SNR3015K-2R7N	2.7	30	70	1.52	1.50	100KHz/0.25V
SNR3015K-3R3M	3.3	20	80	1.32	1.36	100KHz/0.25V
SNR3015K-4R7M	4.7	20	125	1.10	1.09	100KHz/0.25V
SNR3015K-5R6M	5.6	20	170	1.05	1.00	100KHz/0.25V
SNR3015K-6R8M	6.8	20	200	0.85	0.85	100KHz/0.25V
SNR3015K-100M	10	20	250	0.72	0.77	100KHz/0.25V
SNR3015K-150M	15	20	350	0.66	0.65	100KHz/0.25V
SNR3015K-180M	18	20	430	0.56	0.59	100KHz/0.25V
SNR3015K-220M	22	20	460	0.52	0.57	100KHz/0.25V
SNR3015K-330M	33	20	780	0.44	0.42	100KHz/0.25V
SNR3015K-470M	47	20	1200	0.35	0.32	100KHz/0.25V

Isat(A):

DC Saturation Current that will cause initial inductance to drop approximately 30% max

Irise(A):

DC Current that will cause an approximata ΔT of 40°C

Ope.Temp.: -40 to 125°C

Measuring Instrument:L:HP4284 Isat:HP4284+42841A DCR:502BC

CUSTOMER APPROVED (客戶確認)	APPROVED (確認)	CHECKED (檢查)	DRAWN (制圖)

ISSUED DATE(出版日期): 20161014

PRINT DATE(出圖日期): 20161014



三禮電子集團控股有限公司

3L ELECTRONIC GROUP HOLDINGS LIMITED

SPECIFICATION FOR APPROVED 樣品承認書



CUSTOMER:

PAGE : 3 OF 3

P/N(料號): SNR3015K-SERIES

YOUR REF. :

Packaging Specifications

1. Carrier Tape Dimensions:

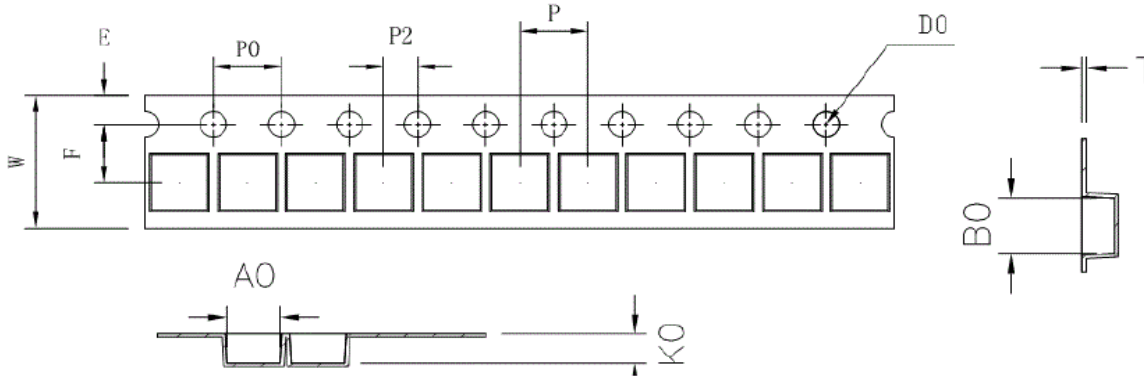

TEM	W	A0	B0	K0	P	F	E	D0	P0	P2	T
DIM	8.00	3.3	3.3	1.9	4.00	3.50	1.75	1.50	4.00	2.00	0.25
TOLE	±0.3	±0.05	±0.05	±0.05	±0.1	±0.05	±0.1	+0.1	±0.1	±0.05	±0.05

2. Reel Dimensions:

Carrier Tape Reel

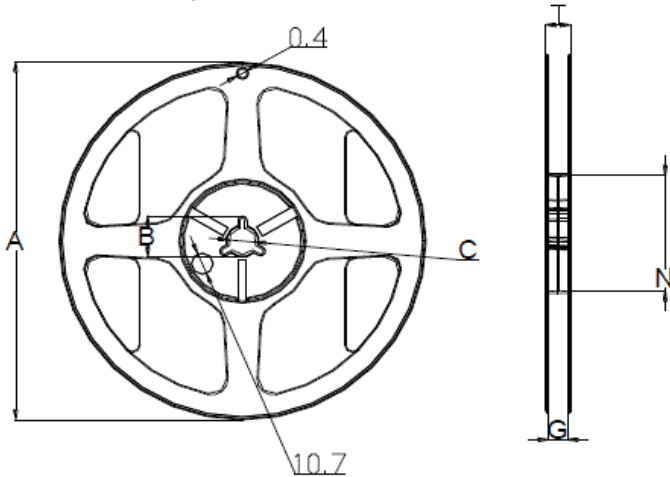

PACKAGE SPECIFICATION:

2KPCS/ Reel

編帶方向 , 如下图所示

編帶方向

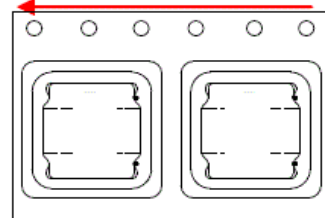

Type	A	B	C	G	N	T
8mm	178	20.7±0.8	13±0.4	9	60	10.8

CUSTOMER APPROVED (客戶確認)

APPROVED (確認)

CHECKED (檢查)

DRAWN (制圖)

工程部
2018.11.07
郭义标

工程部
2018.11.07
钟海珊

工程部
2018.11.07
程燕桥

ISSUED DATE(出版日期): 20161014

PRINT DATE(出圖日期): 20161014